

LOC	DIST	REVISIONS					
F	00	P	LTN	DESCRIPTION	DATE	OWN	APVD
		D1		MARKINGS UPDATE	23MAY2011	OB	OD
		D2		CLARIFICATION	06SEP2013	OB	IS
		D3		ADD PN	27MAY2015	OB	IS
		D4		ADD PN	15OCT2015	OB	IS

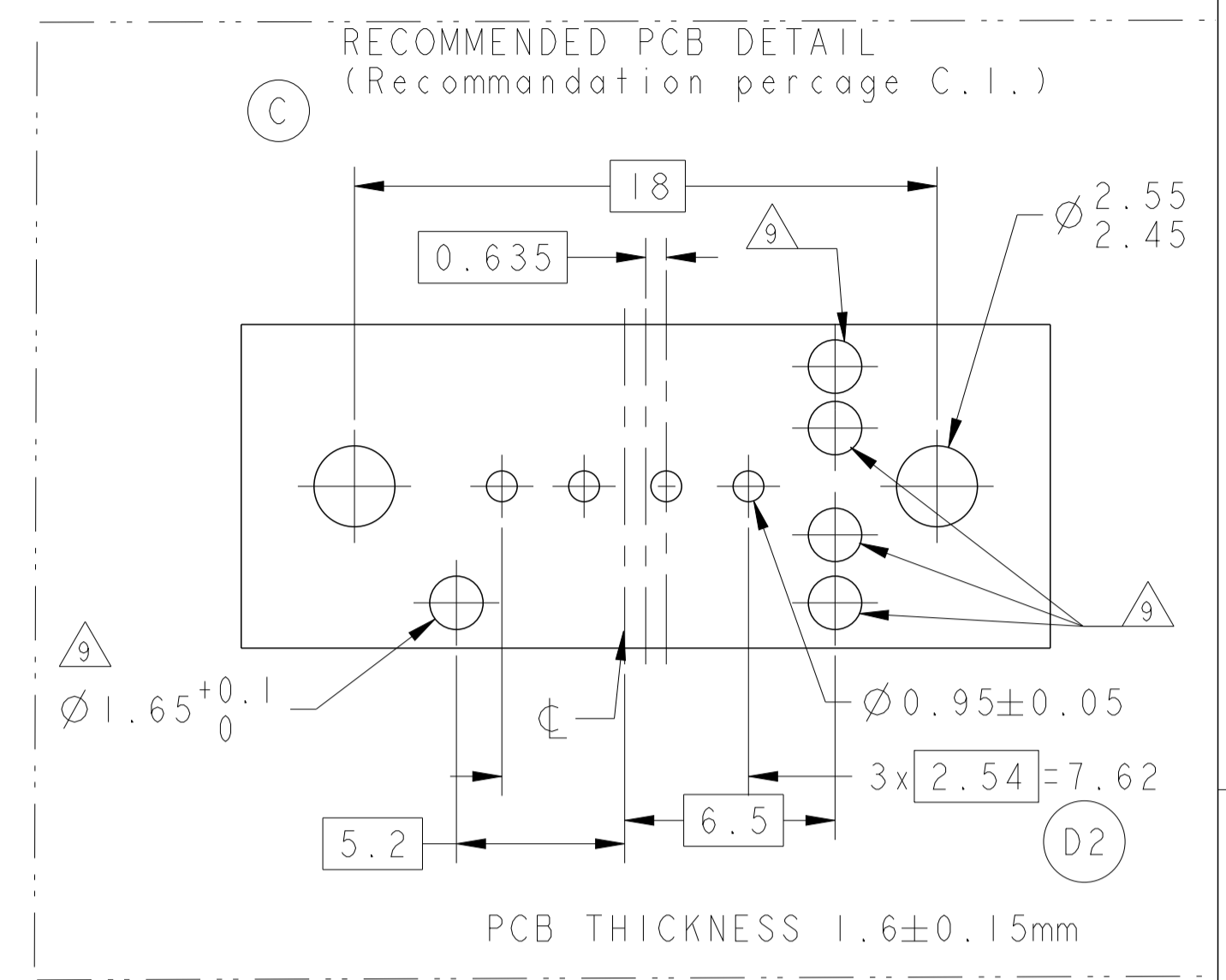
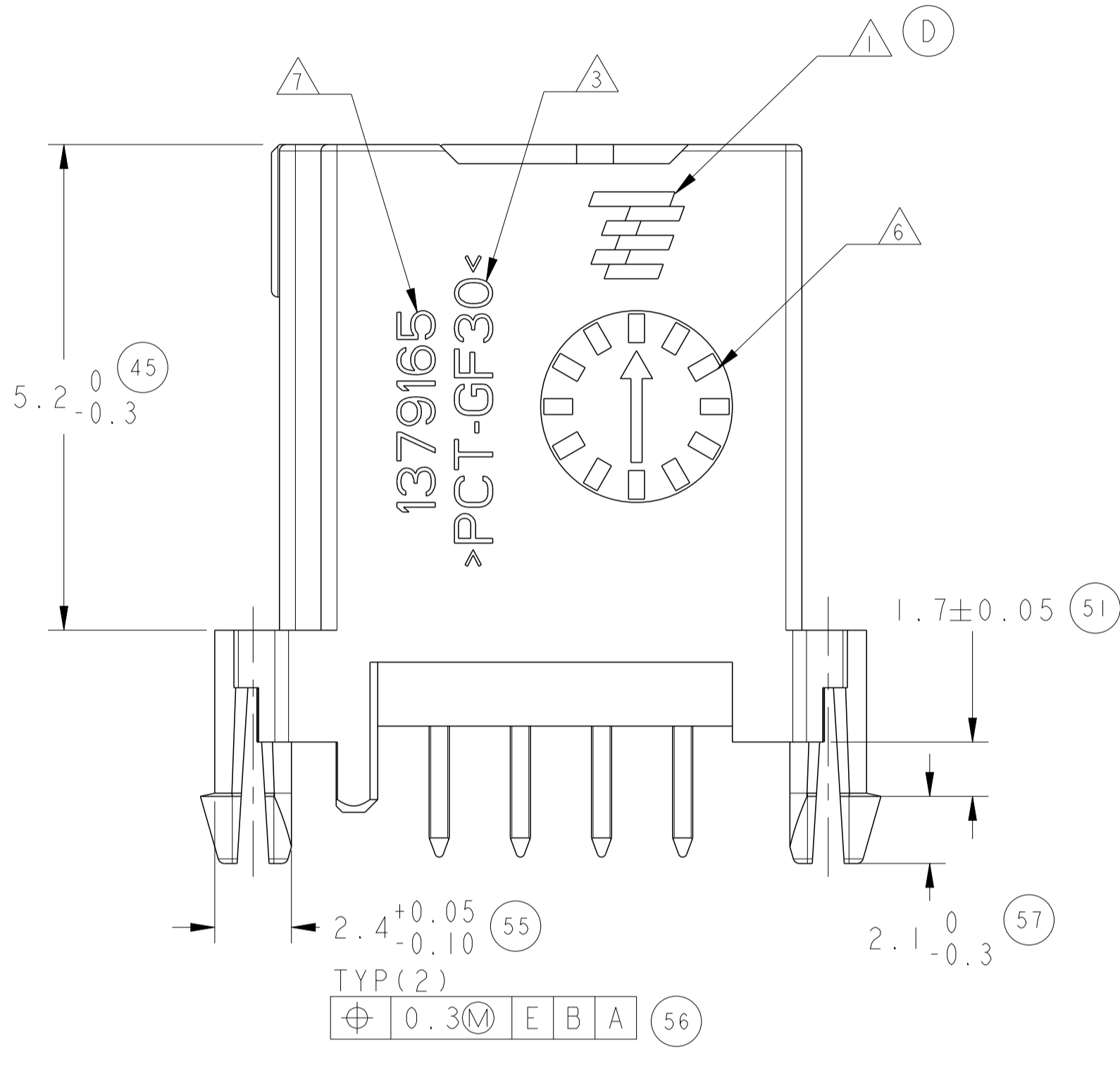
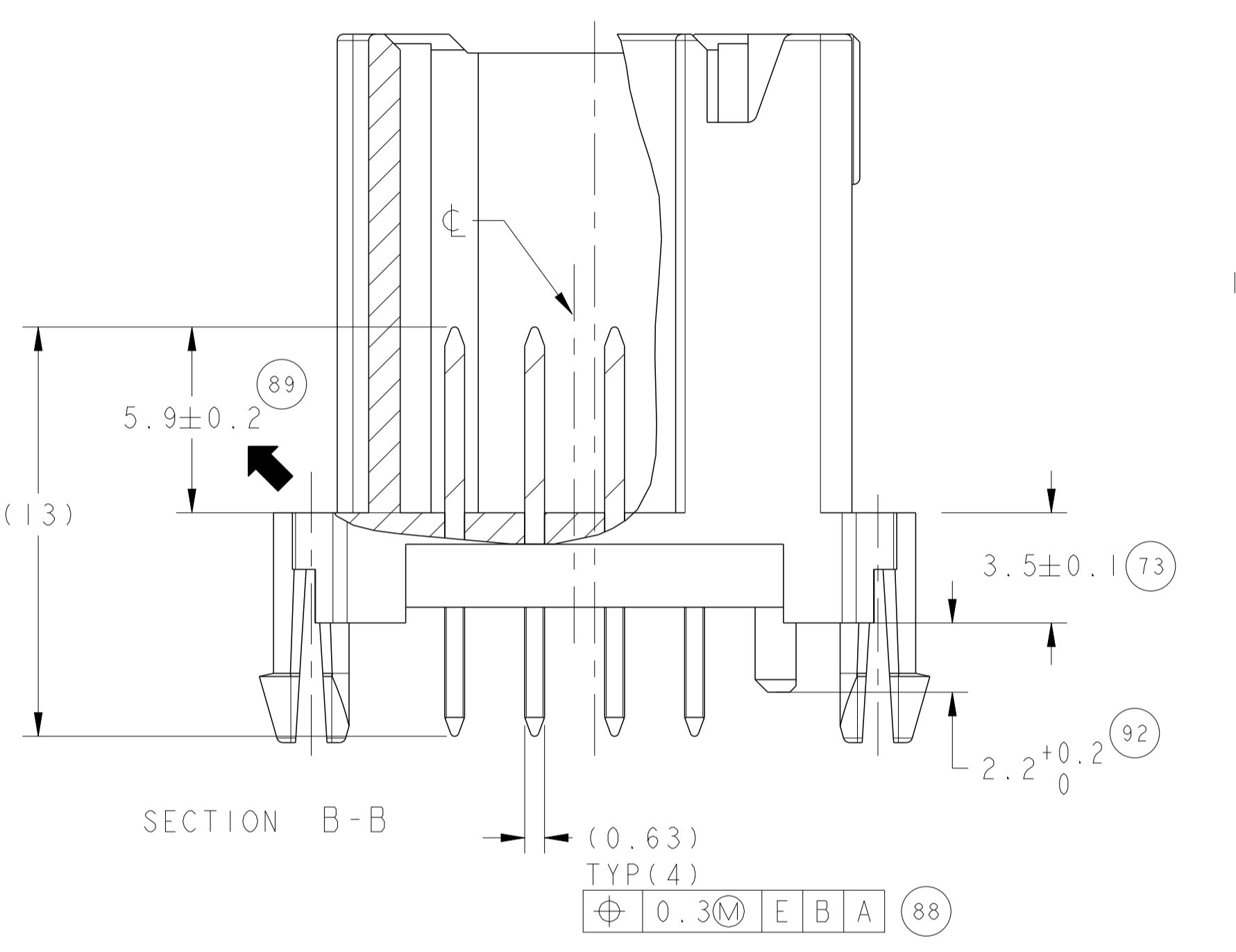
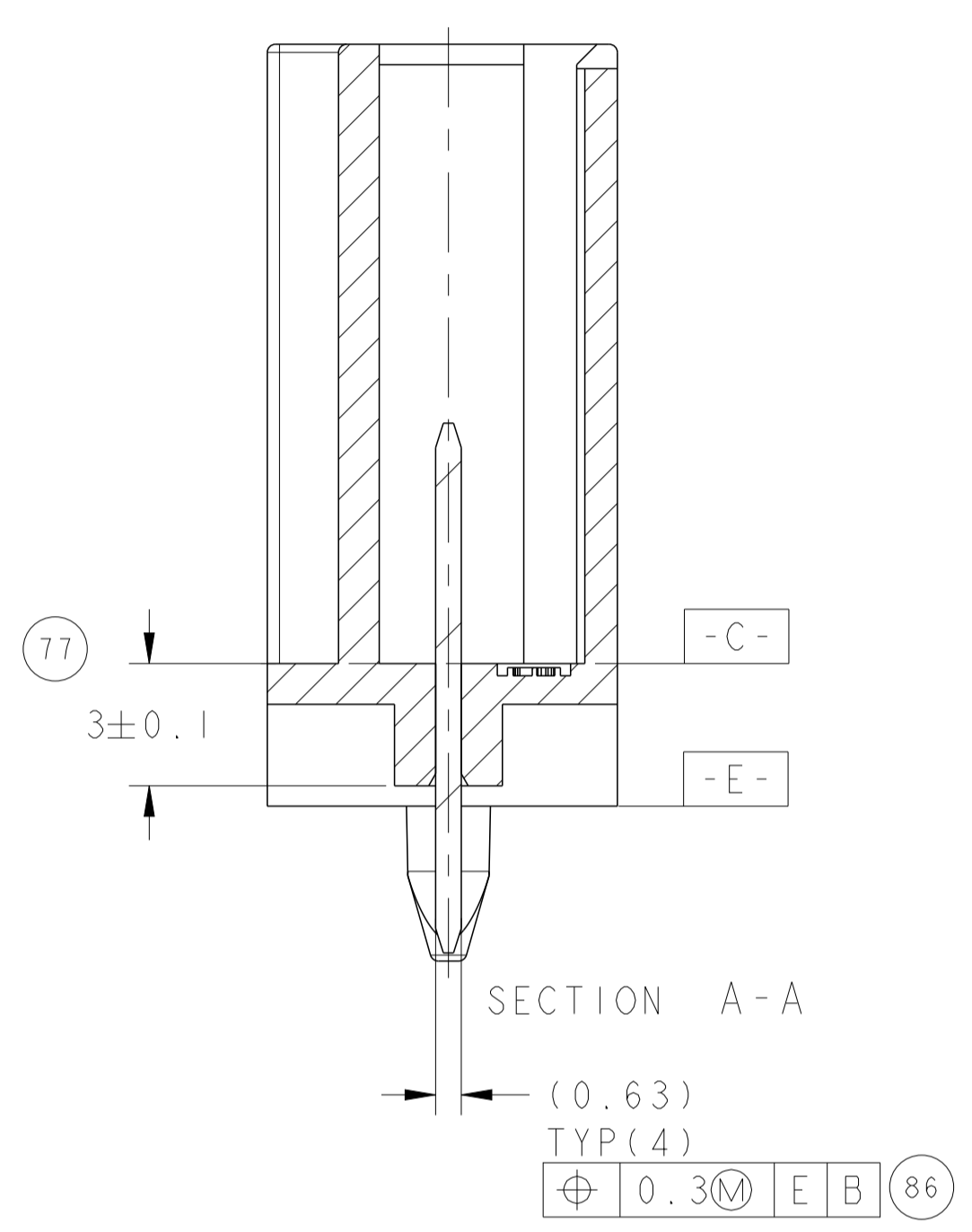
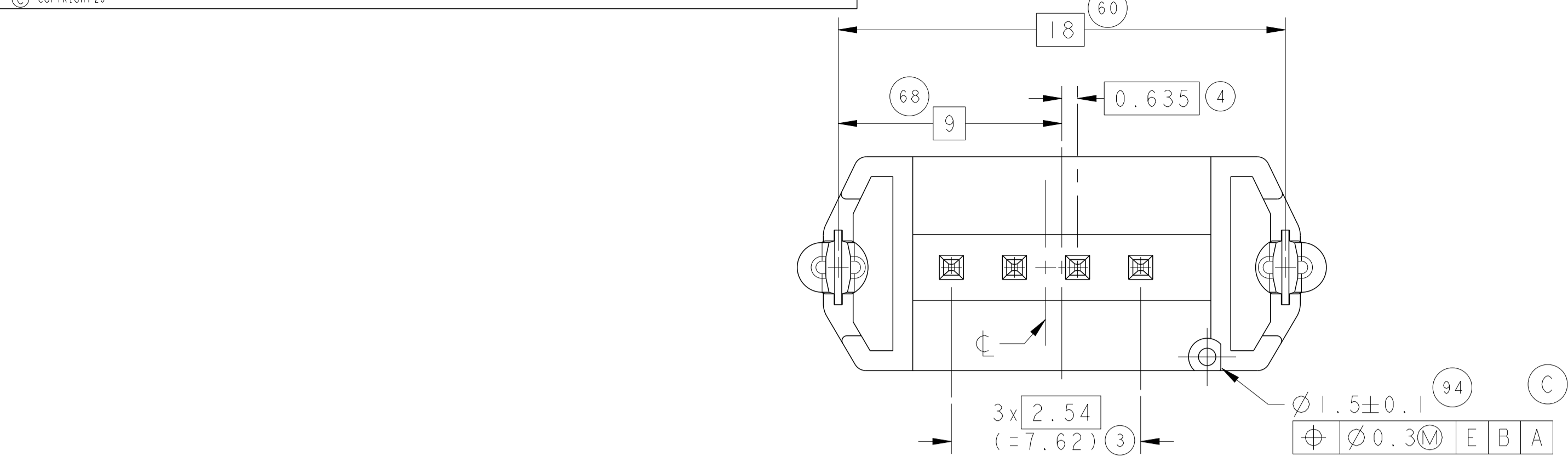

1379165-3
AS SHOWN

NOTES:

- 1 TE STAMP
Logo TE
- 2 CAVITY IDENTIFICATION 1,2,3,4
Repere d'alveole 1,2,3,4
- 3 MATERIAL IDENTIFICATION
Marquage matiere
- 4 MOLD REVISION STATUS
Indice de revision de moule
- 5 MOLD CAVITY NUMBER
Numero d'empreinte du moule
- 6 DATE CODE
dateur
- 7 TE PN
Reference TE
- 8 PCB THICKNESS
Epaisseur CI: 1.6mm
- 9 OPTIONAL HOLE DEPENDING ON CODING
Trou optionnel dependant du codage
- 10 CAPABILITY DIMENTIONS
cotes pour capabilities

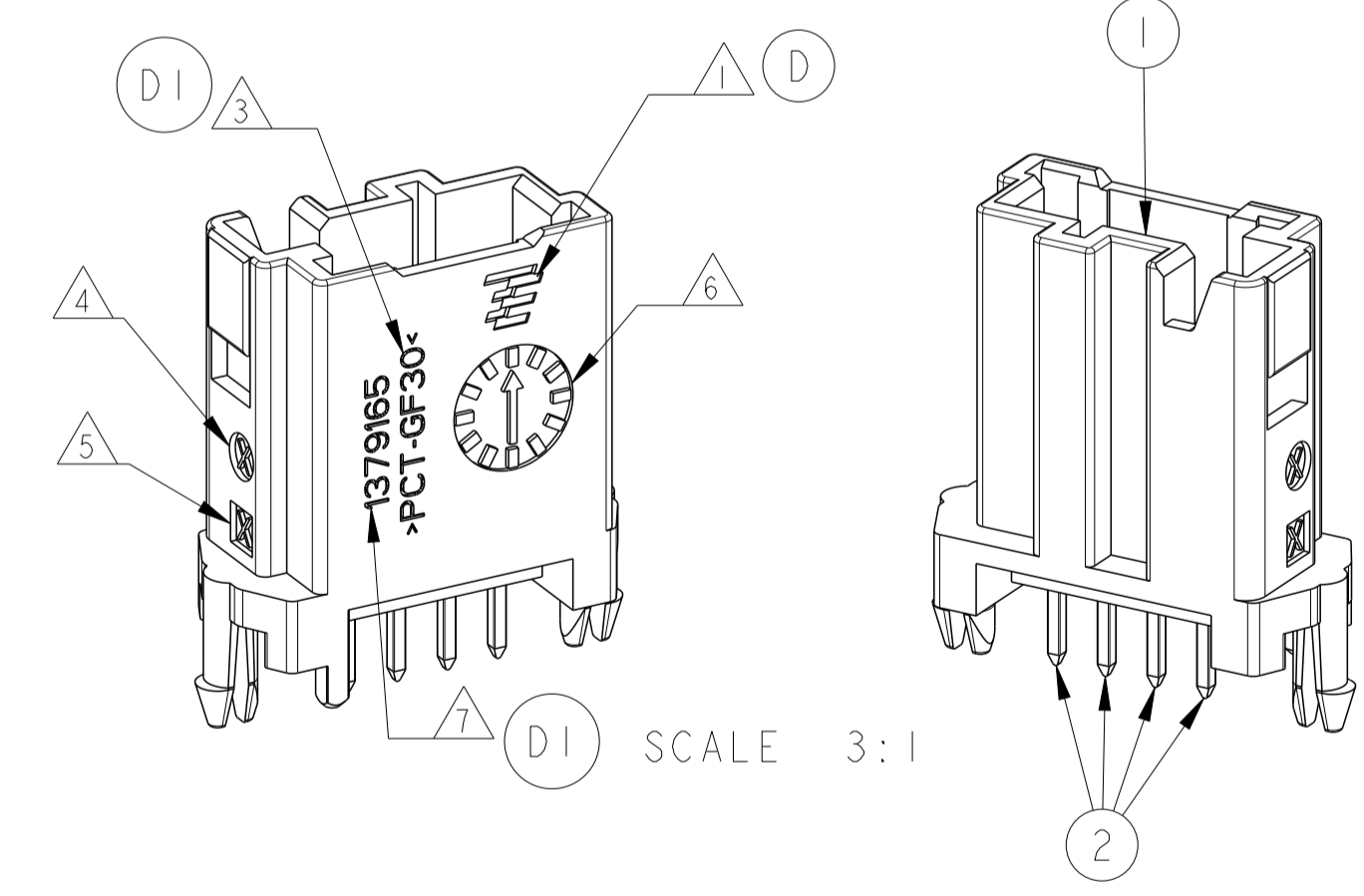
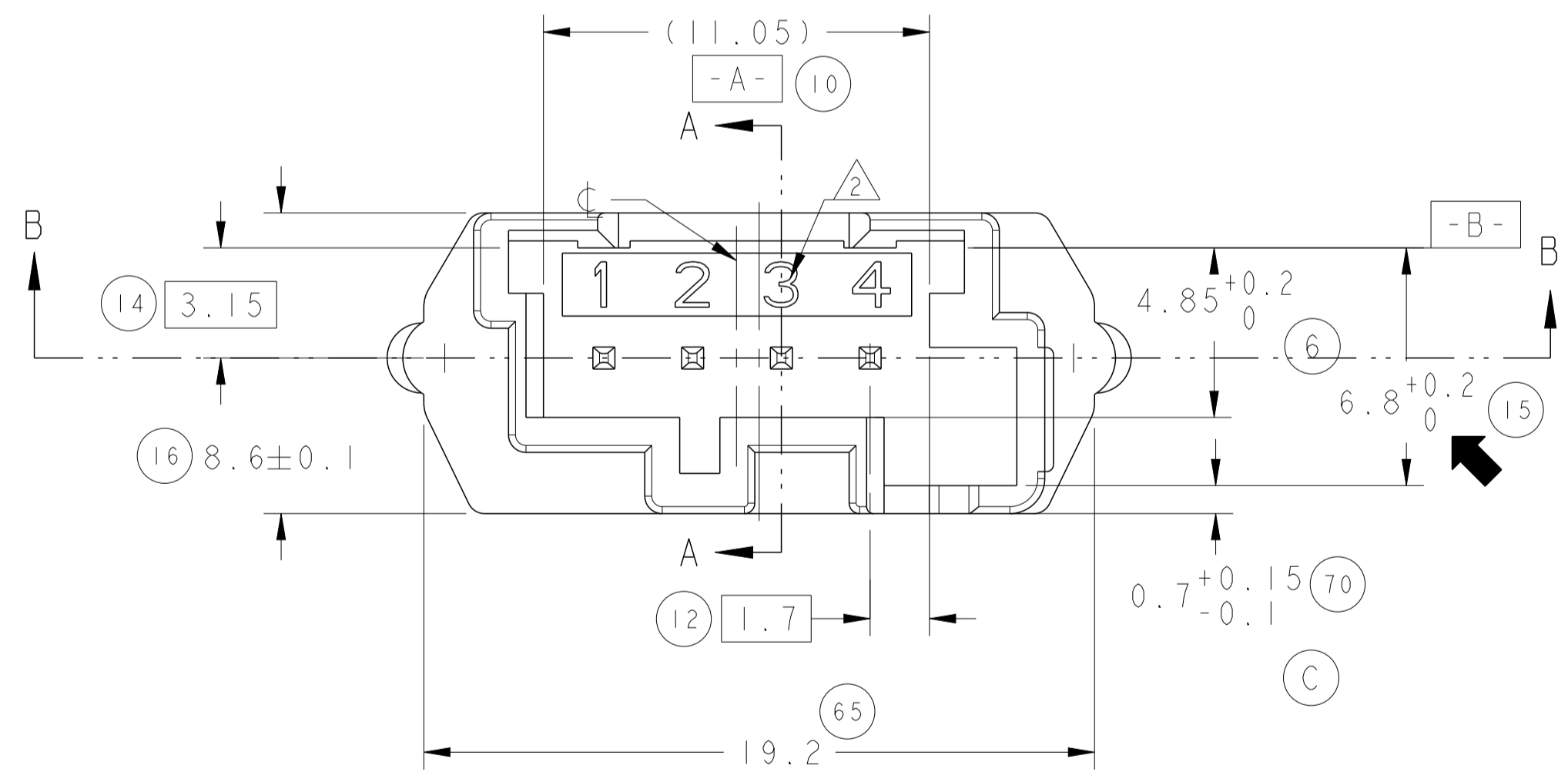

KEYING TABLE (Table de detrompage) (C1)

COLOR	BLACK (NOIR)	WHITE (BLANC)	BLUE (BLEU)	YELLOW (JAUNE)	GRAY (GRIS)	BROWN (MARRON)	BLACK (NOIR)
PN WITH PACKAGING ON TRAY	1379165-1	1379165-2	1379165-3	1379165-4	1379165-5	1379165-6	1379165-7
PN WITH PACKAGING ON STICK	1379165-1	1379165-2	1-1379165-3	1-1379165-4	1-1379165-5	1-1379165-6	1-1379165-7 (D3)
PN WITH PACKAGING ON CARRIER TAPE	2-1379165-1 (D4)	2-1379165-2 (D4)	2-1379165-3 (D4)	2-1379165-4 (D4)	2-1379165-5 (D4)	2-1379165-6 (D4)	2-1379165-7 (D4)

SEE TABLE Voir table	SEE TABLE Voir table	4	PIN MQS	CuSn6	2
		1	4W MQS HEADER Embase 4V MQS	PCT GF30%	1
ASSEMBLY PN PN enssemble	COLOR couleur	QTY qte	DESIGNATION	MATERIAL Matiere	ITEM rep

THIS DRAWING IS A CONTROLLED DOCUMENT.		OWN J. L. LAQUERRE	01DEC2000	TE Connectivity
DIMENSIONS: mm		CHK J. LAQUERRE	05JAN2001	
TOLERANCES UNLESS OTHERWISE SPECIFIED:		APVD J. REVILL	05JAN2001	NAME 4W MQS HEADER POSITIVE MATE
0 PLC ±0.3		PRODUCT SPEC		
1 PLC ±0.3		APPLICATION SPEC		SIZE CAGE CODE DRAWING NO A100779C=1379165
2 PLC ±0.3		WEIGHT		
3 PLC ±0.3		CUSTOMER DRAWING		RESTRICTED TO
4 PLC ±0.3		SCALE 4:1	SHEET 1 OF 1	REV D4
ANGLES ±2°				
FINISH				